



2011

**ADDITIONAL
RULES
WAKEBOARD
BOAT**

INDEX

1	General Information.....	3
2	Categories.....	4
3	Running Order & Heat System	5
4	Equipment.....	6
5	Re-Rides	7
6	Protests.....	7
7	Use of Video.....	8
8	Competition Format.....	8
9	Wakeboard Course	9
10	Double-Up.....	10
11	Obstacles	11
12	Boat Speed & Rope Length.....	12
13	Falls	12
14	Homologation	13
15	Registration.....	14
16	Officials	14
17	E&A Wakeboard Ranking List	14
18	Rules for Officials	15
19	E&A Championships	21
20	Appendixes	24

1 GENERAL INFORMATION

1.1 Applicability of the Rules

The rules set forth here govern wakeboard competitions sanctioned by the International Waterski & Wakeboard Federation Europe and Africa. It is requested that Federations establish rules as close to these rules as possible. Whenever the masculine is used, the same shall be construed as meaning the feminine where the context so requires.

These IWWF E&A Additional Rules Wakeboard Boat are supplementary to the general IWWF E&A regulations including the Bye-Laws, Rules of Eligibility, Anti-Doping Policy, Letter of Agreement and Obligations for Titled Events, and Guidelines. In case of conflict between a regulation in these Additional Rules and a general IWWF E&A regulation, the latter shall apply. The general IWWF E&A regulations are of significance for organizers of, as well as judges and riders at wakeboard events, and must be considered.

1.2 Variations from the IWSF Technical Rules

The IWWF E&A Wakeboard Additional Rules may make variations from the IWWF Technical Rules that do not affect the recorded scores of the competition or the homologation of the competition. Examples of acceptable variations are those to entry requirements, familiarization, method of draw, number of events or rounds, number in finals, method of determining event placement and/or overall and team placement.

1.3 Exceptions to the Rules

Where compliance with the rules is not feasible, the Chief Judge shall with the approval of the majority of the Judges, make the necessary changes. Such changes will be announced at a rider's meeting, and by posting. The Chief Judge shall send a report to the Wakeboard Council to explain these changes to the rules. Where the rules are definite and feasible, a vote of the Judges to decide whether to enforce any provision is prohibited.

1.4 Drug Testing

All competitors must agree to be subject to doping control. Specific policies and procedures regarding doping control shall be detailed in the Medical Regulations of the International Waterski & Wakeboard Federation.

1.5 Unsportsmanlike Conduct

Any rider or official whose conduct is deemed unsportsmanlike or whose conduct may cause discredit to the IWWF, either on or off the competition site, before, during, or after the competition, may be disqualified (rider) or banned (official) from all the competition including completed events and/or be subject to a fine to be determined by the IWWF E&A bureau, by a two-thirds majority vote of the Judges. Any and all infractions can also be punishable by disqualification of the whole team.

Unsportsmanlike conduct includes, but is not limited to: use of vulgar language in public, public tantrums, not riding to fullest potential, failure to attend designated functions or events, consuming alcoholic beverages during the competition, competing under false pretences, concealing significant injuries or health problems, or criticize judges' scores.

1.6 Unsafe Rider Disqualification

No rider shall be allowed to compete or to continue to compete if, in the opinion of the Chief Judge or Safety Director and a majority of the judges, his competing would be a danger to himself or other riders in the competition. During the competition at any time the Chief Judge may, or the Safety Director may request the Chief Judge to, halt the competition for a poll of the judges in regard to a rider's actions or conditions. Whenever practical, the advice of a doctor should be obtained.

1.7 Licenses

Each National Federation must provide to their riders the IWWF E&A wakeboarding license free of charge, which permit their athletes to take part at international events, with the exception of the titled events (E&A Championships or World Championships). National Federations can order the licenses through the IWWF E&A Wakeboard Boat Council website www.wakeboardcouncil.com, and they can get the password by asking the IWWF E&A bureau. National Federations also have to provide the license to their national and international officials. From 2004 the license is free of charge.

1.8 Discharge of Liability

On each national or international event, all competitors, or if the rider is under 18 years of age its parent or team captain, must sign a discharge of liability for the organizer and the host federation in case of accident, material damages, or moral or physical tort, in the domain of the competition. All organizations, federations, persons or institutions involved in the organization of an event who encounter an illicit deed of a competitor, are obligated to use the local Constabulary or judicial authorities in order to judge all litigations and charges against the competitor. A copy of the filed report shall be forwarded to his own federation who will prohibit the competitor's access to all events as long as the litigations are not definitely settled.

1.9 Suggestions

Riders are encouraged to bring up suggestions and questions of their concern to any judge or to the IWWF E&A Wakeboard Boat Council in any way possible. Contact information to officials and members of the Council is available on the Council's website at www.wakeboardcouncil.com. Suggestions regarding these rules must be brought up before November 1st for changes of the rules for the following year.

2 CATEGORIES

The Chief Judge with the approval of the majority of the judges may open a category with less than six riders. In such case the results of those riders will not be accounted for in the team scoring.

A rider's age as of 1st. of January the current year will be used to determine age bracket.

2.1 Youngsters (Boys & Girls)

9 years old and under. If a rider was born in the following years, then they qualify for this category:

If a rider was born in 2001 and after.

2.2 Boys

10 to 14 years old. If a rider was born in the following years, then they qualify for this category:

2000 - 1999 - 1998 - 1997 - 1996

2.3 Girls

10 to 14 years old. If a rider was born in the following years, then they qualify for this category:

2000 - 1999 - 1998 - 1997 - 1996

2.4 Junior Men

15 to 18 years old. If a rider was born in the following years, then they qualify for this category:

1995 - 1994 - 1993 - 1992

2.5 Junior Ladies

15 to 18 years old. If a rider was born in the following years, then they qualify for this category:

1995 - 1994 - 1993 - 1992

2.6 Open Division - Men

No age restriction.

2.7 Open Division - Ladies

No age restriction.

2.8 Masters - Men

30 years old and over: If a rider was born in 1980 and before.

2.9 Masters - Ladies

30 years old and over: If a rider was born in 1980 and before.

2.10 Masters 2 - Men

39 years old and over: If a rider was born in 1971 and before.

This category can only be opened if there are enough riders to open both Master - Men and Masters 2 - Men.

2.11 Masters 2 - Ladies

39 years old and over: If a rider was born in 1971 and before.

This category can only be opened if there are enough riders to open both Master - Ladies and Masters 2 - Ladies.

3 RUNNING ORDER & HEAT SYSTEM

3.1 General

Wakeboard competitions will use a heat system. The heat system to be used at competitions is an integrated part of these rules and is published by the IWWF E&A Wakeboard Boat Council as an addendum.

3.2 Qualification Rounds

In qualifying rounds, the running order will be randomly determined by numbered ping pong balls or by a similar system. The number of riders in each heat is dependent on the total number of riders entered. A percentage of the riders from each heat will then go through to the, semi-finals and finals.

3.3 Running of the Competition

A rider will be disqualified from all the competition if he fails to be on hand and ready to ride with an untangled rope when the boat is prepared to start. That means when the rope is fixed and the boat starts to be in line with the course. Should a rider be disqualified for any reason, he will not be permitted to participate in the remainder of the competition, i.e. if he misses his turn in the qualifying rounds, he will not be permitted to compete in the last chance qualifiers (LCQ).

In the case where a rider is not available or has been disqualified, a one-minute delay shall be granted to the next rider in the starting order if he was not on the starting jetty at the time of disqualification. If more than one rider has been disqualified, the time allotted to the next rider shall be one minute for each rider disqualified.

Simplified examples:

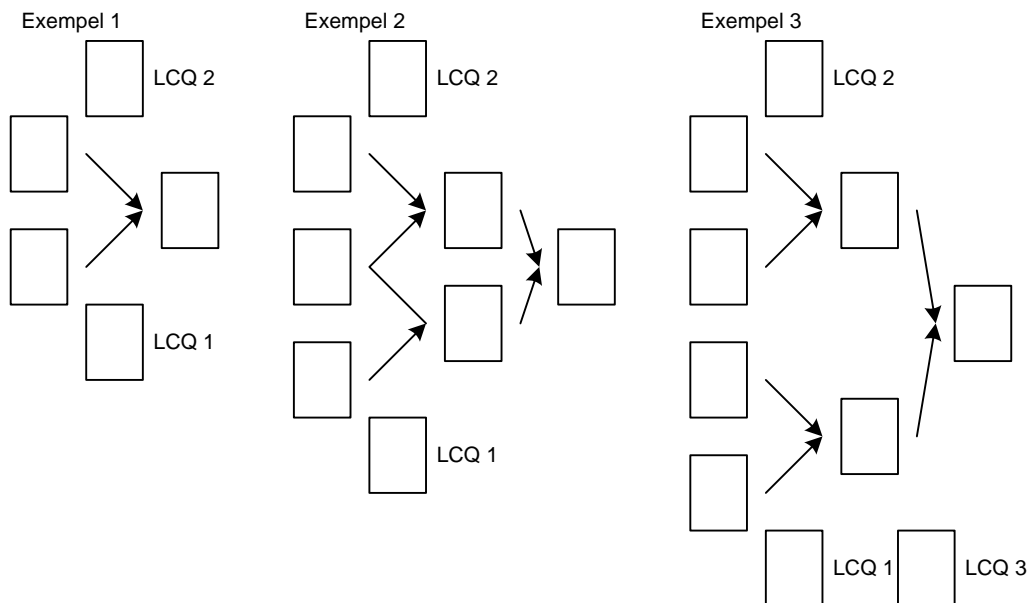

4 EQUIPMENT

4.1 General

All personal equipment is subject to the approval of the Chief Judge and Safety Director, named at each event.

4.2 Life Vest

All competitors must wear a life vest. It is responsibility of each rider to ensure their life vest meets the following specifications:

1. It must float the rider
2. It must be constructed so as to provide adequate protection from impact damage to the ribs and internal organs.

4.3 Towlines

Riders must provide their own handles and ropes which must be of a non-stretch material.

4.4 Helmets

Riders must wear a suitable helmet if they choose to hit any of the obstacles in the wakeboard course. If a rider hits an obstacle during the competition, including practice, without a helmet, the rider will be disqualified from all of the competition. If a rider wishes to hit any obstacles, the rider must start the routine with a helmet on.

4.5 Damaged Equipment

A rider is fully responsible for his personal equipment. If a rider has damaged his equipment, he will have four minutes to repair the equipment. The Chief Judge will have the final say as to whether the equipment has failed. The damaged equipment can be repaired at the jetty only. It is the responsibility of the driver to go directly to the jetty. The time begins when the rider gets onto the jetty. The rider must have both feet back in his bindings before the 4 minutes elapses or his routine is over.

In the event that a rider realises his equipment has been damaged, the rider may throw the handle to indicate that he wishes to repair the equipment. This will, however, constitute one fall if it occurs in the wakeboard course. After the equipment has been repaired, the rider will resume his routine at the point where the handle was thrown. If a rider falls and then discovers that the equipment is damaged, the boat will resume the routine at the location of the fall after the equipment has been repaired.

5 RE-RIDES

It is the sole responsibility of the rider to ask for a rerun.

When unfair conditions occurs of artificial causes, which, in the opinion of the chief judge and a majority of the Boat Judges, adversely affects a rider, he shall be granted the option of a re-ride only on the pass affected. In case the unfair conditions occurs at an obstacle the rider will get a re-ride for that obstacle only and onwards. Re-rides will not be granted if a rider's personal equipment fails.

Re-rides must be taken immediately. If a rider is given a second re-ride, he may elect to take a five-minute rest, during which the next rider in order will perform his routine. The re-ride shall be taken at the conclusion of the rider's routine during which the five-minute rest period expires.

Requests for re-rides may be initiated by a Boat Judge for the event before the next rider starts or may be initiated, as soon as possible, by the rider or his team representative and shall be decided as soon as practicable thereafter. If, in the opinion of the Boat Judges for the event, the request was not initiated as soon as possible after the rider has ridden, the request shall be denied.

Re-ride requests will not be permitted if they are based on variations in weather or water conditions.

6 PROTESTS

Protests shall be made to the Chief Judge only by a team representative. Protest must be made in writing, must state the reason(s) for the protest, and must be filed as soon as possible, but no later than 10 minutes after the occurrence or after the results of the event are announced in case the protest is regarding the results.

Protests shall be allowed only for failure of the judges and calculators to comply with these rules and only if this non-compliance with rules have an adverse effect on a rider. No protests shall ever be permitted regarding the scoring by the Boat Judges.

A correction of an error in the computation of scores shall not be considered a protest and the correction shall be made on the approval of the Chief Judge and Calculator within 10 minutes after the results are announced. It's up to the Chief Judge only to agree the inspection of scoring sheets

Protests must be accompanied by the approximate equivalent in local currency of 50 Euros - This amount will be refunded if the protest is considered reasonable or upheld by the Judges.

7 USE OF VIDEO

Due to the subjective scoring nature & spirit of wakeboarding or wakeskating, video footage of any kind will not be used by Judges, riders or team representatives to resolve any disputes. Judges can only use the video footage before scoring a rider's routine.

8 COMPETITION FORMAT

8.1 General

Each rider shall be allowed two passes through the wakeboard course during which time the rider may perform any routine he or she chooses. The rider will be judged on three subjective style categories to arrive at a single combined score.

8.2 Judging of the routine begins

When the rider enters the wakeboard course and ends when the rider exits the wakeboard course, falls for the last time, or completes his/her double-up (finals only).

8.3 Boat (Scoring) Judges

The Chief Judge will designate three Boat Judges, to be seated in the tow boat, to score each rider's routine.

8.4 Scoring

Riders are encouraged to perform a smooth flowing routine with a wide variety of tricks. Each manoeuvre should be executed as cleanly as possible and taken to its limit.

Each one of the three boat judges should make notes of each rider's score in each score category on a scale from zero (0) to ten (10). A rider can get a minimum of 0.1 points.

Each score category represents the rider's performance on water as well as on obstacles when such are used.

8.4.1 Execution - 33.3 Points

This reflects the level of perfection to which each manoeuvre was performed, as well as the successful completion of the routine with a minimum number of falls.

8.4.2 Intensity - 33.4 Points

This reflects how big the moves were performed, as well as the technical difficulty of the tricks executed.

8.4.3 Composition - 33.3 Points

This reflects the overall composition of the routine in terms of the rider's ability to perform a variety of manoeuvres in a flowing, creative sequence

8.5 Calculation of Scores

The average method of calculating will be used. Scores from all categories (Execution, Intensity, and Composition) of a rider's routine are added together to produce a judge's total score. All three judges' total scores are then averaged to produce a final score for the rider on a scale from zero (0) to one hundred (100) that displays the overall impression of the routine performed.

All boat judges shall sign the calculated scores before they are made official.

The Calculator shall keep the original scoring sheets from all judges and all heats for at least six months after the end of the competition.

9 WAKEBOARD COURSE

9.1 Course Buoys

The Chief Judge will specify the buoys to be used for the wakeboard course.

9.2 Course Dimensions - Without Obstacles

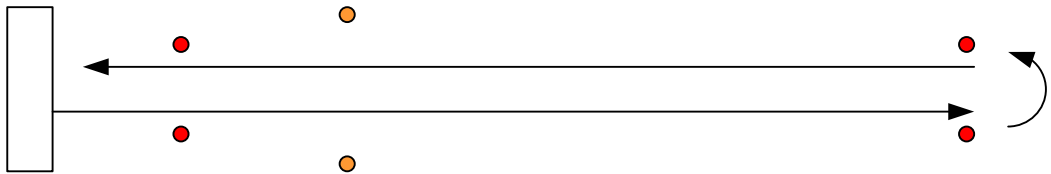

A pair of start buoys 10 meters apart shall establish the approximate area of the beginning of the wakeboard course from each direction. The end of the pass shall be signified by another pair of buoys 10 metres apart. The distance from the start and end buoys, will be approximately 370 metres (38 seconds at 35 km/hour or 22 miles/hour). These course dimensions will be used where practical. Bright orange buoys are recommended for the start and end buoys. A rider's first and second pass will begin after he or she rides around either the right or left hand start buoy. The affected pass will not be scored if the rider does not ride around the start buoy before his or her first or second pass.

9.3 Cut-Off Buoys

A pair of cut off buoys, approximately 50 metres apart, will indicate the point after which the tow boat will not be able to get up to speed for a rider to continue his run in the second pass. Bright green buoys will be used for the cut off buoy. The position of the cut off buoys will be determined by the Chief Judge and Chief Boat Driver.

9.4 Proceeding Through the Two Wakeboard Passes

On the first pass the boat shall follow as closely as possible the path specified by the Chief Judge for the event, such path to include the preparation time before each pass. On the second pass shall be in the opposite direction from the first pass.

9.5 Course Dimensions - With Obstacles

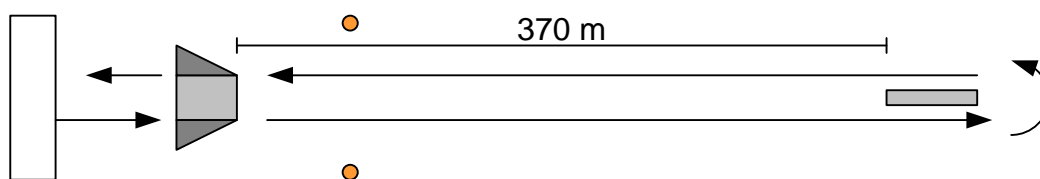

The end of an obstacle shall establish the approximate area of the beginning of the wakeboard course from each direction. The end of the pass shall be signified by the beginning of another obstacle. The distance between the start and end obstacles, will be approximately 370 metres (38 seconds at 35 km/hour or 22 miles/hour). These course dimensions will be used where practical.

9.6 Cut-Off buoy

A pair of cut off buoys, approximately 50 metres apart, will indicate the point after which the tow boat will not be able to get up to speed for a rider to continue his run in the second pass. Bright green buoys will be used for the cut off buoy. The position of the cut off buoys will be determined by the Chief Judge and Chief Boat Driver.

9.7 Proceeding through the two wakeboard passes

On the first pass the boat shall follow as closely as possible the path specified by the Chief Judge for the event, such path to include the preparation time before each pass. On the second pass shall be in the opposite direction from the first pass.

9.8 A rider's wakeboard pass will end

When he falls for the last time or when he passes the obstacle. A rider's last trick will be scored if he leaves the crest of the wake before passing the second obstacle.

Any rider who swims down the course to gain advantage over a fellow competitor will not be picked up. This will be the end of his or her routine.

10 DOUBLE-UP

By a majority of the judges the double-up for one or more categories may be cancelled completely if this should jeopardize the safety or the efficient running of the event.

Each rider who qualifies for the wakeboard finals will be given a double-up. It is the sole responsibility of each competitor to communicate to the driver before leaving the jetty whether he or she would like a left or right double-up. Re-rides will not be granted due to any miscommunication between the rider and driver. In the event that the boat provides a double-up in an incorrect direction, the rider must wave off the double-up and not attempt any manoeuvre. If any manoeuvre is attempted, which includes cutting at the wake, the rider will be deemed to have accepted his or her double up. If a rider waves off the double-up, the boat will then turn around, and proceed with a double-up in the correct direction. Re-rides will not be granted for turbulent water in this instance. However, if through driver error, then a 3 minute delay will be granted to the rider, to allow the water to calm back to suitable conditions.

In the final, if a rider's first fall occurs beyond the cut-off (3/4) buoys, the rider will have a double-up, but the rider will not be allowed to hit the obstacle at the end of the course, if any, for safety reason.

An unsuccessful double-up will not affect the score of a rider's routine. But a successful double-up will be counted as a bonus and will add to the rider's score.

11 OBSTACLES

There shall be a maximum of two different obstacles in a wakeboard course.

- Slider or rainbow slider
- Kicker
- Fun box

11.1 Rainbow Slider Or Flat Bar Slider:

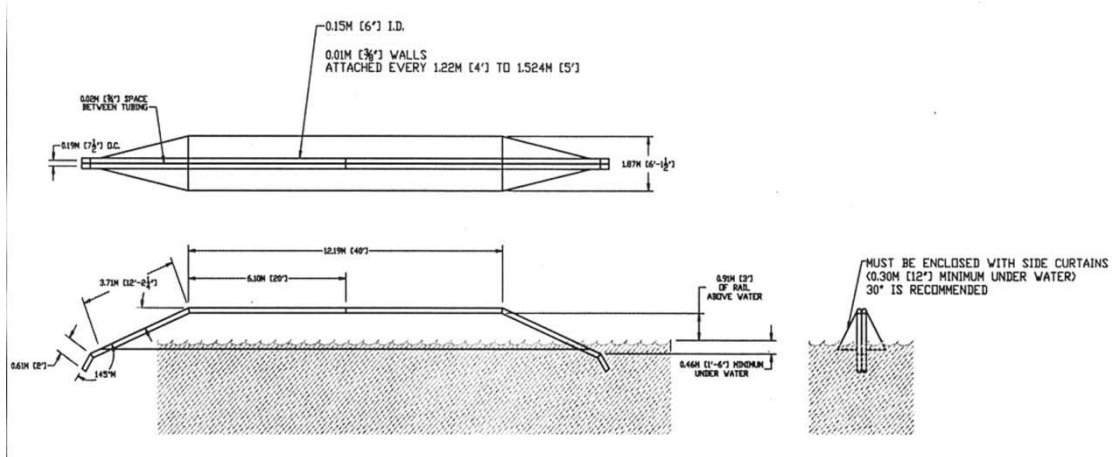

Sliding surface: 2 x 0.15 metre inner dimension high density polyethylene tubings or 0.20 – 0.30 metre flat bar.

Height: From 0.70 metres to 0.90 metres

Length of Flat Bed: From 10.00 metres to 12.00 metres

Incline: From 12 degrees to 22 degrees

11.2 Kicker:

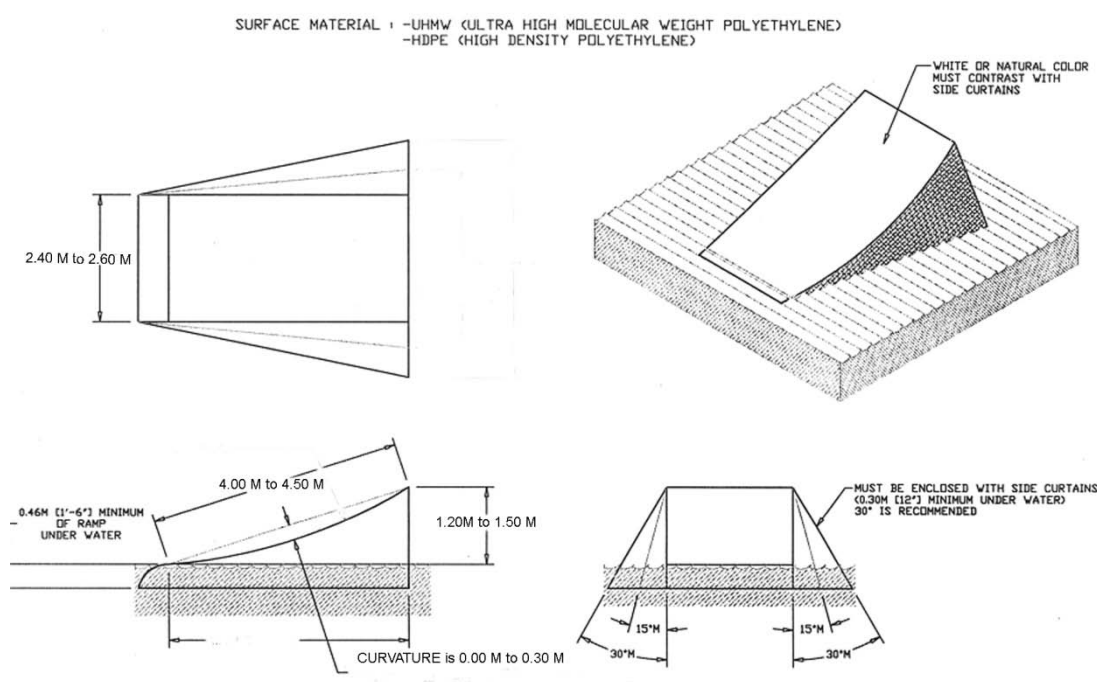

Height: From 1.20 metres to 1.50 metres

Length of Surface: 4.00 metres to 4.50 above waterline

Width at All Points: 2.40 metres to 2.60 meters

Curvature: 0.00 to 0.30 metre from straight line

11.3 Fun Box

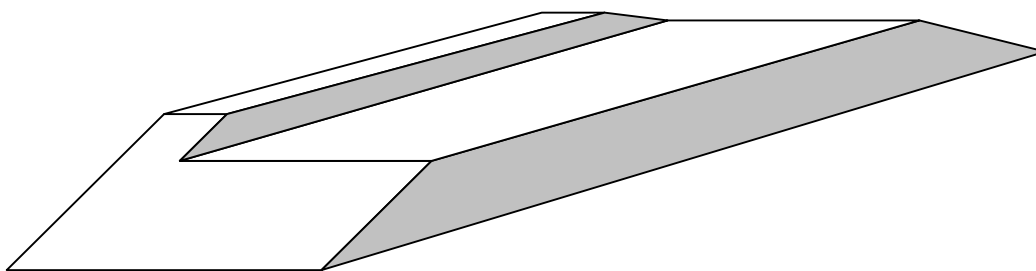

However, in certain cases, the Chief Judge with the majority of judges may make the decision where to place these obstacles in the wakeboard course. Riders are encouraged to hit these obstacles to add variation to their routines. Riders competing in all categories will be permitted to hit the obstacles.

It shall be possible for the organizer of an event to, after consultation with, and approval from the IWWF E&A Wakeboard Boat Council, to use additional or altered obstacles in the wakeboard course.

12 BOAT SPEED & ROPE LENGTH

Each rider shall receive his choice of a constant speed through the course for each pass, and preferred rope length. The boat speed, assuming it is held constant before entering the course, is the rider's responsibility. The rider is allowed to adjust the speed of the boat during the routine. The driver shall adjust the speed as quickly as possible after getting notice of the rider's sign.

The rider shall use the standardized signals and not cause the boat to stop, if possible. Deliberate use of delaying tactics will be considered unsportsmanlike conduct and will subject the rider to penalty or disqualification. The following signals apply in addition to well-known riding signals. Use in combination as applicable.

1. Thumb(s) up means go faster
2. Thumb(s) down means go slower
3. Pointing at an item of equipment means a problem with it
4. Pointing back toward object means debris in water
5. Raising hand overhead means request for re-ride
6. Fallen rider must signal to tow boat and safety boat that he/she is OK and/or injured.

It is the responsibility of the Rider to clearly communicating to the Officials in the boat or jetty marshal what rope length he or she desires. It may prove useful for the smooth running of the competition marking the correct rope length with a piece of tape or similar.

13 FALLS

13.1 Out-Of-Course Falls and Handle-Throw

A rider may have one out-of-course fall only before the start of his first pass.

The rider may also have one handle-throw before the start of his first pass which will also count as one out-of-course fall.

If a rider throws the handle prior to the start of his first pass to indicate that his rope was incorrectly put on the wrong loop by the officials or Judges in the boat, it will not count as an out-of-course fall.

An out-of-course fall or handle throw before the start of the second pass will count as one in-course fall.

In case of an out-of-course fall or handle throw before the start of a rider's first pass the boat will start again from the jetty.

Two falls: A rider may have a maximum of two falls during a routine. Should a fall occur, the boat will pick up the rider to proceed with the routine. The rider will not be picked up after a second fall.

13.2 Obstacles

When obstacles are used, a rider's pass will end when he or she has fallen either twice on the water or twice on the obstacles.

During qualifications, LCQ, and semifinal if a first fall occurs after the $\frac{3}{4}$ bouy the ruder will not have any end obstacle.

13.3 Example One

A rider falls on a trick off the wake, and then falls on the slider, the rider will be picked up. But his pass will end if he falls on either an obstacle or water trick.

13.4 Example two

A rider falls off the rainbow slider, and then falls off the kicker but has no previous water falls. His pass ends.

13.5 Readiness

The rider must be ready to ride immediately upon the boat's return after the first fall, an out-of-course fall, or handle-throw.

14 HOMOLOGATION

14.1 General

A competition is homologated through the following steps:

1. The competition is announced to and sanctioned by the IWWF E&A Wakeboard Boat Council.
2. The competition is put on the official calendar at www.wakeboardcouncil.com.
3. The competition is run in accordance with these rules.
4. A homologation dossier, complete results for all heats, including qualification rounds, and a list of all participating riders including date of birth and nationality, is sent to the Wakeboard Boat Council as soon as possible after the completion of the competition, but at the end of September the same year at the latest.

Results from all homologated competitions will be included in the official IWWF E&A ranking for the same year.

Any sanctioned or homologated event, excluding the National Championships, open to international riders must be homologated as an international event to the IWWF E&A. If any international rider has competed at the National Championships, the rider has to be excluded from the results.

In addition, it is up to the Chairman of the Wakeboard Council to find other agreements.

14.2 Fees

Homologation fees for national and international events, as well as the additional fees for cash prize competition shall be applicable in accordance with the IWWF E&A Bye-Laws.

14.3 National Competitions and National Championships

For homologated national competitions there must be 3 judges, all must be recognised by the IWWF E&A Wakeboard Boat Council.

14.4 International Events

If five or more countries are represented at the event at least two of the judges must be of International Level 1 standard, and the rest of at least International Level 2 / National Level 1 standard.

If less than five countries are represented at the event at least one of the judges must be of International Level 1 standard, and one of at least International Level 2 / National Level 1 standard.

14.5 E&A Championships

All judges must be of International Judge (Level 1) standard.

15 REGISTRATION

All competitors must be members of their respective Federation. A competitor must be able to prove his or her membership in his or her National Federation at any homologated event. Prior to competing, a competitor must sign a participation contract and understand the nature of the sport and its special risks, particularly in the format. It is the responsibility of the competitor to register with the designated registration person and show proof of Federation membership before riding. Competitors must disclose to the event organiser any special medical conditions, including but not limited to, injuries in the past or present or other pre-existing medical conditions. A document may be sign by all riders at the registration.

16 OFFICIALS

The minimum number of officials in the panel at a competition are:

- Chief Judge
- 2 Assistant Judges
- Calculator
- Boat Driver
- Jetty Marshall

17 E&A WAKEBOARD RANKING LIST

An IWWF E&A Wakeboard Boat ranking list will be created and results collected from homologated national events and tours, National Championships, international homologated events, the E&A Championships, and the IWWF World Championships. Each National Federation must provide to their national and international riders the IWWF E&A wakeboarding license, which permit their athletes to take part in the ranking list. National Federations can order the licenses through the IWWF E&A Wakeboard Council website www.wakeboardcouncil.com, and they can get the password by asking the IWWF E&A bureau. From 2004 the license is free of charge. The IWWF E&A Wakeboard Boat Council must receive a homologation dossier together with complete results from each homologated competition.

18 RULES FOR OFFICIALS

18.1 Ballast

The total additional weight in the boat will be determined by the Chief Judge and the Chief Driver.

18.2 General Responsibilities of Officials

All wakeboard officials, regardless of level and function, must attend one Seminar each year or act as an official at their level and in their function during the year to retain their status.

All officials must forward suggestions and questions of a rider's concern to the appropriate national association or to the IWWF E&A Wakeboard Boat Council.

All officials must be members of their federation and remain so in order to retain their position as an official.

All official at a competition shall act as representatives of the panel in all situations during the competition and shall in no situation act as representatives of a national team.

No official is allowed to participate as a rider at a titled event.

Only International Judges (International Level 1) are allowed to act as instructors at Judges & Officials Seminars, or International Level 1 Calculator as calculation instructors at the same. All Judges & Officials Seminar, and the instructors at the seminar, must be sanctioned by the IWWF E&A Wakeboard Boat Council.

18.3 Degradation of Judges

Any official may have his or her official status downgraded or be suspended by a majority decision of the IWWF E&A Wakeboard Boat Council if acting in conflict with decisions made by the IWWF E&A Wakeboard Boat Council, acting in conflict with the spirit of the sport, or has been proven to act in an unprofessional manner. Before such a decision by the IWWF E&A Wakeboard Boat Council is put into effect, the affected official shall get the opportunity to defend his or her position in writing.

18.4 Assistant Judge (National Level 3)

18.4.1 Seminars

The prospective judge should actively seek out and attend judging seminars associated with the sport.

18.4.2 Responsibility

Assistant judges are designated by and on the responsibility of their respective federations. All candidates must be 16 years or over.

18.4.3 Functions

Assistant judges are qualified to officiate at all national competitions up to but not including National Championships.

18.4.4 Examinations

A short introductory course will result in the candidate becoming an Assistant Judge culminating in a written examination - with an 80% pass mark. Assistant Judges will be encouraged to progress on to become National Level 2 standard.

18.5 National Judge (National Level 2)

18.5.1 Responsibility

National Judges are designated by and on the responsibility of the IWWF E&A Wakeboard Boat Council. All candidates must be aged 18 years or over. (Prior to taking their exam all candidates must have acted as an assistant official at 4 National Calendar competitions).

18.5.2 Functions

National Judges are qualified to judge at all national competitions including National Championships.

18.5.3 Examinations

The IWWF E&A Wakeboard Boat Council is responsible for organising and correcting examinations for candidates. The exam consists of two parts, one written and one practical.

18.5.4 Written Examination

The exam tests that the candidate has a basic knowledge of the rules. An 80% pass mark is required.

18.5.5 Practical Examination

The exam is a trick reading examination that must take place either during a seminar or the course of a single event. The examiner present must be of an International Level 1 standard. The candidate shall write the trick runs of different competitors at which he takes the examination. He is not required to judge whether tricks are performed according to the rules or not.

Each of the following will be counted as one error:

- Omitting to write a trick performed by a competitor during the pass or immediately before or after the pass
- Writing a trick, which was not performed by the competitor
- Writing a trick other than the trick the competitor performed

Only passes which contain three or more inverts will be considered.

18.6 National Chief Judge (National Level 1, International Level 2)

18.6.1 Responsibility

National Chief Judges are designated by and on the responsibility of the IWWF E&A Wakeboard Boat Council. All candidates for National Chief Judge must be aged 18 or over. Prior to taking their exam, all candidates must have acted as an official at 4 National Calendar competitions.

18.6.2 Functions

National Chief Judges are qualified to judge at National Championships and International Competitions but not including titled events.

18.6.3 Examinations

The IWWF E&A Wakeboard Boat Council is responsible for organising and correcting examinations for candidates for nomination as National Chief Judges. The exam consists of two parts, one written and one practical.

18.6.4 Written Examination

The exam tests that the candidate has a fair knowledge of the rules. An 80% pass mark is required.

18.6.5 Practical Examination

The exam is a trick reading examination that must take place either during a seminar or the course of a single event. The examiner present must be of an International Level 1 standard. The candidate shall write the trick runs of different competitors at which he takes the examination. He is not required to judge whether tricks are performed according to the rules or not.

Each of the following will be counted as one error:

- Omitting to write a trick performed by a competitor during the pass or immediately before or after the pass
- Writing a trick, which was not performed by the competitor
- Writing a trick other than the trick the competitor performed

Only passes which contain three or more inverts will be considered..

18.6.6 Renomination

The conditions of renomination of officials as National Chief Judges are the responsibility of the IWWF E&A Wakeboard Boat Council.

18.6.7 Maintaining Qualification

A National Chief Judge must judge at a minimum of 2 National events or 1 International event (each year), or attend a Judging Seminar to maintain his or her qualification.

18.7 International Judge (International Level 1)

18.7.1 Responsibility

International Level 1 Judges are designated by and on the responsibility of the IWWF E&A Wakeboard Boat Council. All candidates for International Judge must be aged 18 or over.

18.7.2 Functions

International Judges Level 1 are qualified to judge at all national and international competitions including titled events.

18.7.3 Examinations

The IWWF E&A Wakeboard Boat Council is responsible for organising and correcting examinations for candidates for nomination as International Judges. The exam consists of two parts, one written and one practical.

18.7.4 Written Examination

The exam tests that the candidate has a good knowledge of the rules. An 80% pass mark is required.

18.7.5 Practical Examination

The exam is a trick reading examination that must take place either during a seminar or the course of a single event. The examiner present must be of an International Level 1 standard. The candidate shall write the trick runs of different competitors at which he takes the examination. He is not required to judge whether tricks are performed according to the rules or not.

Each of the following will be counted as one error:

- Omitting to write a trick performed by a competitor during the pass or immediately before or after the pass
- Writing a trick, which was not performed by the competitor
- Writing a trick other than the trick the competitor performed

Only passes which contain three or more inverts will be considered.

18.7.6 Renomination

The conditions of renomination of officials as International Judges are the responsibility of the IWWF E&A Wakeboard Boat Council.

18.7.7 Maintaining Qualification

An International Judge must judge at a minimum of 2 National events or 1 International event (each year), or attend a Judging Seminar to maintain his or her qualification.

18.8 National Calculator

18.8.1 Responsibility

National Calculators are designated by and on the responsibility of their respective federation. All candidates must be 16 years old or older.

18.8.2 Functions

National Calculators are qualified to act as calculator at all national competitions up to but not including National Championships.

18.8.3 Examination

A short introductory course that covers these rules, the heat system, and the calculation program will result in the candidate becoming an National Calculator, culminating in a written examination - with an 80% pass mark. National Calculators are encouraged to progress on to attaining an International Level 2 standard.

18.9 International Level 2 Calculator

18.9.1 Responsibility

International Level 2 Calculators are designated by and on the responsibility of the IWWF E&A Wakeboard Boat Council. All candidates must be 18 years of age or older. Prior to taking their exam all candidates must have acted as a National Calculator at 2 National Calendar competitions.

18.9.2 Functions

International Level 2 Calculators are qualified to act as calculator at all national competitions including National Championships, as well as at international competitions, but not including titled events.

18.9.3 Examination

The IWWF E&A Wakeboard Boat Council is responsible for organising and correcting examinations for candidates. The examination consists of two parts, one written and one practical. The instructor and examiner must be of an International Level 1 standard.

18.9.4 Written Examination

The written examination tests that the candidate has a basic knowledge of the heat system, and these rules. An 80% pass mark is required.

18.9.5 Practical Examination

The practical examination will test the candidate's ability to smoothly and efficiently organizing and running a competition as a calculator. It will cover organizing riders into categories and heats, entering riders and scores into the calculation program, as well as handling common situation that might appear during a competition.

18.10 International Level 1 Calculator

18.10.1 Responsibility

International Level 1 Calculators are designated by and on the responsibility of the IWWF E&A Wakeboard Boat Council. All candidates must be 18 years of age or older.

18.10.2 Functions

International Level 1 Calculators are qualified to act as calculator at all national and international competitions including titled events.

18.10.3 Examination

The IWWF E&A Wakeboard Boat Council is responsible for organising and correcting examinations for candidates. The examination consists of two parts, one written and one practical. The instructor and examiner must be of an International Level 1 standard.

18.10.4 Written Examination

The written examination tests that the candidate has an advanced knowledge of the heat system, these rules, as well as other rules of the IWSF. An 80% pass mark is required.

18.10.5 Practical Examination

The practical examination will test the candidate's ability to smoothly and efficiently organizing and running a competition as a calculator. It will cover, registering of riders, organizing riders into categories and heats, entering riders and scores into the calculation program, as well as handling common and complex situation, that might appear during a competition. It will also test the candidate's judgement in these situations.

18.10.6 Maintaining Qualification

An International Level 1 Calculator must act as a calculator at a minimum of 2 national events or 1 international event each year, or attend a Judging Seminar, to maintain his or her qualification.

18.11 National Boat Driver

18.11.1 Responsibility

National Boat Drivers are designated by and on the responsibility of their respective federation. All candidates must be 16 years old or older, and must have extensive experience of driving a boat.

18.11.2 Functions

National Boat Drivers are qualified to act as boat driver at all national competitions up to but not including National Championships.

18.11.3 Examination

A short introductory course that covers these rules, handling of a wakeboard boat, and the running of a competition will result in the candidate becoming an National Boat Driver, culminating in a written examination - with an 80% pass mark. National Boat Drivers are encouraged to progress on to attaining an International Level 2 standard.

18.12 International Level 2 Boat Driver

18.12.1 Responsibility

International Level 2 Boat Drivers are designated by and on the responsibility of the IWWF E&A Wakeboard Boat Council. All candidates must be 18 years of age or older, and must have extensive experience of driving a boat with a rider behind. Prior to taking their exam all candidates must have acted as a National Boat Driver at 2 National Calendar competitions.

18.12.2 Functions

International Level 2 Boat Drivers are qualified to act as boat driver at all national competitions including National Championships, as well as at international competitions, but not including titled events.

18.12.3 Examination

The IWWF E&A Wakeboard Boat Council is responsible for organising and correcting examinations for candidates. The examination consists of two parts, one written and one practical. The instructor and examiner must be of an International Level 1 standard.

18.12.4 Written Examination

The written examination tests that the candidate has a basic knowledge of these rules, thorough understanding of the responsibilities of the boat driver, and advanced knowledge of the functioning of a wakeboard boat. An 80% pass mark is required.

18.12.5 Practical Examination

The practical examination will test the candidate's ability to smoothly and efficiently running a competition as a boat driver. It will cover handling of the boat, ballast and weight distribution, wake shape, the wakeboard course, obstacles and driving passed obstacles, as well as handling common situation that might appear during a competition.

18.13 International Level 1 Boat Driver

18.13.1 Responsibility

International Level 1 Boat Drivers are designated by and on the responsibility of the IWWF E&A Wakeboard Boat Council. All candidates must be 18 years of age or older and must have extensive experience of driving a boat with a rider behind privately and at competitions.

18.13.2 Functions

International Level 1 Boat Drivers are qualified to act as boat driver at all national and international competitions including titled events.

18.13.3 Examination

The IWWF E&A Wakeboard Boat Council is responsible for organising and correcting examinations for candidates. The examination consists of two parts, one written and one practical. The instructor and examiner must be of an International Level 1 standard.

18.13.4 Written Examination

The written examination tests that the candidate has a advanced knowledge of these rules as well as other rules of the IWSF, thorough understanding of the responsibilities of the boat driver, and advanced knowledge of the functioning of a wakeboard boat, and engines, maintenance and repairs, as well as the specifics of different wakeboard boats. An 80% pass mark is required.

18.13.5 Practical Examination

The practical examination will test the candidate's ability to smoothly and efficiently running a competition as a boat driver. It will cover handling of the boat on and off the water, maintenance and repair of the boat and engine, ballast and weight distribution, wake shape, the wakeboard course, obstacles and driving passed obstacles, as well as handling common and complex situation, that might appear during a competition. It will also test the candidate's judgement in these situations.

18.13.6 Maintaining Qualification

An International Level 1 Boat Driver must act as a boat driver at a minimum of 2 national events or 1 international event each year, or attend a Boat Driving Seminar, to maintain his or her qualification.

19 E&A CHAMPIONSHIPS

19.1 Rules

Rules for the E&A Championships and the IWWF World Championships are available at the Secretary or at www.wakeboardcouncil.com.

19.2 Competition Site During Wakeboard E&A Championships

Once the Wakeboard Course has been settled down in accordance with the Chief Judge, (three days prior the event) use of the site is not permitted until the completion of the competition.

There will be no official familiarisation. The organiser, however, has the option to provide paid practice before the start of the competition. The start of the competition may vary depending on the number of entries. If using the official boat and/or wakeboard course and/or obstacles it is the responsibility of the organizer.

Registration will close at 20:00 two days before the start of the competition.

19.3 Categories at the Wakeboard E&A Championships

There will be a minimum of 6 riders required to open a category. What categories that will be opened will only be determined after the end of registration.

A rider will only be allowed to enter one category, either the appropriate age-group category or the Open category.

The Chief Judge will ensure that all riders' passports are checked for verification of age.

The Chief Judge with the approval of the majority of the Judges may open a category with less than six riders. In such case the results of those riders will not be accounted for in the team scoring.

19.4 Entry Requirements for Wakeboard E&A Championships

19.4.1 Rider Eligibility

Only riders from Region E&A are eligible to enter the E&A Wakeboard Championships.

A Federation may select its team in any manner it desires; however, each team member must be a citizen or applying for citizenship of the country which the Federation represents. In case of doubt as to the nationality of a competitor, the Judges normally will refer to his passport. If a rider does not have a passport from the country he is representing, he must prove residence in the country for at least five years and membership in an affiliated club of the Federation. Each Federation shall certify that all members of its team meet these qualifications.

19.4.2 Competition Entry

A rider may compete in the Wakeboard E&A Championships as either a team representative or individual.

19.4.3 Team Scoring

A team will comprise of a maximum of 8 riders, with a maximum of 2 riders in the same category. Although it is encouraged to have a mixed participation with men and women riders within a team, it is not compulsory. Federations must nominate their team riders before the specified deadline posted in the first Wakeboard E&A Championships' Bulletin distributed by the host Federation. The best 6 scores will be taken for country classification. In case of equality will be taken the best 7 scores.

19.4.4 Individual Entries

Riders who are not part of a team may compete as individual. An individual rider's entry must be submitted through his respective Federation. Federations will decide the criteria for an individual rider's entry. There is currently no restriction to the number of riders who enter the Wakeboard E&A Championships as individuals.

19.5 Team Scoring at Wakeboard E&A Championships

With the use of the heat system, there will be instances where riders have finished in a joint position with a rider in a different heat. The relevant placing points will therefore be given to each individual.

Please note that points are not awarded after each qualification round. Each team rider will be awarded the following point's dependant on his place in the final, semi final or LCQ.

1st place	100 points
2nd place	80 points
3rd place	65 points

4th place	55 points
5th place	45 points
6th place	35 points
7th place	30 points
8th place	25 points
9th place	20 points
10th place	17 points
11th place	14 points
12th place	11 points
13th place	8 points
14th place	6 points
15th place	5 points
16th place	4 points
17th place	3 points
18th place	2 points
19th place	1 point

20th place and all subsequent riders receive 1 point each.

Should a rider be disqualified for any reason the rider's nation's team will, as a result of this, consist of one rider less. The rider can, thus, not be replaced by another rider.

19.6 Team Composition

The chief calculator shall collect the team composition before the end of the registration, and shall post the team composition before the start of the competition. No protest concerning the team composition will be permitted after the start of the competition.

19.7 Officials

The minimum number of officials in the panel at the E&A Championships:

- Chief Judge
- Assistant Chief Judge
- 5 Judges
- Chief Calculator
- Assistant Calculator
- Chief Boat Driver
- Assistant Boat Driver
- Jetty Marshall

19.8 Schedule Changes & Cancellation of Events during Wakeboard E&A Championships

Changes in the schedule during the competition shall be made only for weather, water conditions, safety, or a similar reason. Such changes will be announced at a riders' or team captains' meeting, and by posting.

The finals of each category must be completed to determine a winner, even if the Judges are obliged to continue it at a different site. If a final cannot be completed, all riders from the event will compete again where and when possible, until a winner is determined

19.9 General Recommendations

19.9.1 Late Entry

A late entry fee of 10 € per day per competitor shall be levied on each entry not received 10 days before the end of registration.

19.9.2 Judges' Clothing

Official clothes for the officials shall be provided for by the organizer for the prize giving ceremony, opening ceremony, and competition.

19.9.3 Bulletin

Every Bulletin must be approved by the Chairman of the IWWF E&A Wakeboard Boat Council before it is distributed.

19.9.4 Transportation

The Organizers are not obliged to provide transport for teams free of charge other than between the official hotel or approved accommodation to and from ceremonies and social functions.

Such transportation shall also be provided free of charge for officials. Renting a car for officials is recommended to the organizers.

19.9.5 Water

Organisers are obligated to provide fresh drinking water for competitors and officials free of charge.

20 APPENDIXES

A number of appendixes are an integral part of these Rules but published and updated as separate documents. These are:

- Ranking Rules
- Pre-Event Homologation Form
- Post-Event Homologation Form